

Overload Protection Equipment

TORQUE LIMITERS

Application Semiconductor manufacturing equipment, textile machinery, printing machinery

Detecting an Overload Reliably and Taking Appropriate Action to Protect the Machine against Overload

This torque limiter detects an overload and disconnects the input side and the output side immediately to protect the machine. Because it is the one-position engagement type, when the overload is removed, the input and output are automatically connected with the same torque in the same indexing position. In contrast to the friction type, this type can be used even in adverse environments.

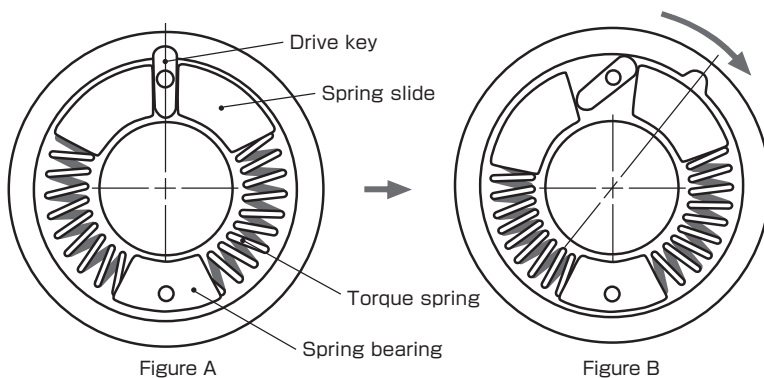

1. Normally the drive key is engaged with the groove of the housing to transmit torque. (Figure A)
2. If an overload is applied, the drive key is tilted against the force of the torque spring and disconnected from the groove of the housing to disconnect the input side and the output side. (Figure B)
3. When the input side and the output side are returned to the original indexing position after removing the overload, the operation can be restarted with the torque that was set originally.
4. The normal and reverse rotation torque can be changed by independently connecting normal and reverse rotation torque springs. (Please contact Miki Pulley for details.)

Available Models

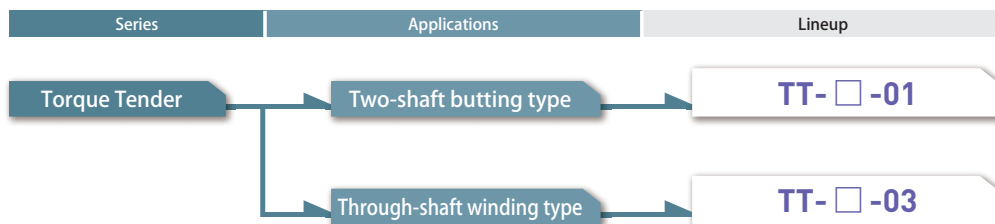

* Torque tender is the name of Miki Pulley's overload protection equipment

COUPLINGS

ETP BUSHINGS

ELECTROMAGNETIC CLUTCHES & BRAKES

SPEED CHANGERS & REDUCERS

INVERTERS

LINEAR SHAFT DRIVES

TORQUE LIMITERS

ROSTA

TT- □ -01 Types (Two-shaft Butting Type)

The two-shaft butting type is made by inserting two shafts from both ends (housing and hub) of the torque tender and securing them with set screws to transmit power and protect the machine against overload.

The two-shaft butting type can also be used as a flexible coupling.

- Set torque: 0.2 to 200 N · m
- Applied shaft diameter: 8 to 50 mm

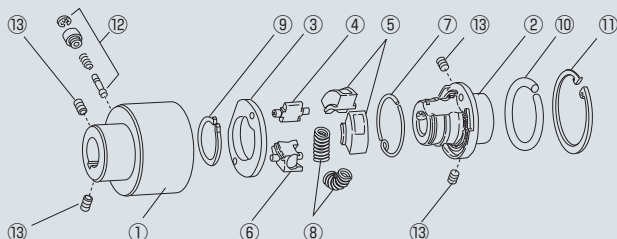
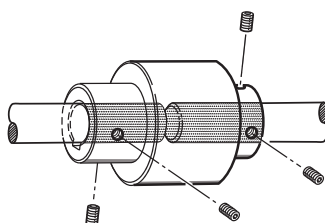

- ① Housing ② Hub ③ Hub ring ④ Drive key ⑤ Spring slide ⑥ Spring bearing
- ⑦ Reset spring ⑧ Torque spring
- ⑨ Stop ring ⑩ Stop ring washer
- ⑪ Stop ring ⑫ Signal pin (option)
- ⑬ Set screws (included)

TT- □ -03 Types (Winding Type)

The winding type is made by inserting the shaft into the inside (hub) of the torque tender and attaching a pulley, sprocket, or gear to the outside of the housing to transmit power and protect the machine against overload.

The shaft is designed to be secured at the center of the main unit so it can be attached even if its end is structured as a through-shaft.

- Set torque: 0.2 to 200 N · m
- Applied shaft diameter: 8 to 45 mm

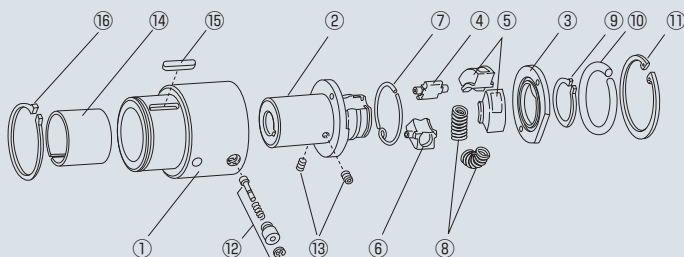
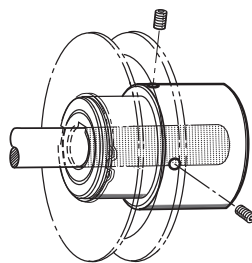

- ① Housing ② Hub ③ Hub ring ④ Drive key ⑤ Spring slide ⑥ Spring bearing
- ⑦ Reset spring ⑧ Torque spring
- ⑨ Stop ring ⑩ Stop ring washer
- ⑪ Stop ring ⑫ Signal pin (option)
- ⑬ Set screws (included) ⑭ Oilless metal
- ⑮ Outer diameter key (included)
- ⑯ Stop ring (included)

MODELS

TT

TT-□-01 Types

Specifications

Model	Size	Set torque value [N·m]										Misalignment		Max. rotation speed [min ⁻¹]	Moment of inertia [kg·m ²]	Mass [kg]
		Spring color										Parallel [mm]	Angular [°]			
		Colorless	Blue	Red	Yellow	White	Gray	Green	Brown	Colorless						
TT-1X-01	1X	0.2	0.5	1.0	1.5	2.0	2.5	3.0	3.5	4.0	0.2	0.5	1800	0.06 × 10 ⁻³	0.3	
TT-2-01	2	1	2	3	4	5	6	7	8	10	0.2	0.5	1800	0.26 × 10 ⁻³	0.7	
TT-2X-01	2X	2	3	5	8	10	12	15	18	20	0.2	0.5	1800	0.52 × 10 ⁻³	1.0	
TT-3-01	3	5	8	10	15	20	25	30	35	40	0.2	0.5	1800	1.23 × 10 ⁻³	1.5	
TT-3X-01	3X	10	16	20	30	40	50	60	70	80	0.2	0.5	1800	1.94 × 10 ⁻³	2.7	
TT-4X-01	4X	20	30	50	80	100	120	150	180	200	0.2	0.5	500	14.8 × 10 ⁻³	6.3	

* The set torque values in the table above are those when the rotation speed is 1500 min⁻¹. The operation torque varies depending on the operating rotation speed. Please check P563.
 * If you need durability for the torque values in the area, select a larger size.

Dimensions

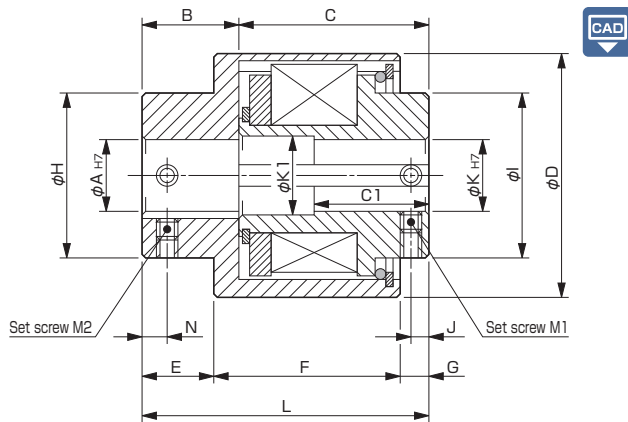

Size	Shaft bore dimensions in compliance with the new JIS standards	
	A	K
1X	10 · 11 · 12 · 14	10 · 11 · 12
2	11 · 12 · 14 · 15 · 16 · 18 · 19 · 20	11 · 12 · 14 · 15 · 16
2X	14 · 15 · 16 · 18 · 19 · 20 · 22 · 24	14 · 15 · 16 · 18 · 19
3	18 · 19 · 20 · 22 · 24 · 25 · 28 · 30	18 · 19 · 20 · 22 · 24 · 25
3X	18 · 19 · 20 · 22 · 24 · 25 · 28 · 30	18 · 19 · 20 · 22 · 24 · 25
4X	19 · 20 · 22 · 24 · 25 · 28 · 30 · 32	19 · 20 · 22 · 24 · 25 · 28 · 30
	35 · 38 · 40 · 42 · 45 · 48 · 50	32 · 35 · 38 · 40 · 42 · 45

Size	Shaft bore dimensions in compliance with the old JIS standards	
	A	K
1X	8 · 10 · 11 · 12 · 14	8 · 10 · 11 · 12
2	11 · 12 · 14 · 15 · 16 · 18 · 19 · 20	11 · 12 · 14 · 15 · 16
2X	14 · 15 · 16 · 18 · 19 · 20 · 22 · 24	14 · 15 · 16 · 18 · 19 · 20
3	18 · 19 · 20 · 22 · 24 · 25 · 28 · 30	18 · 19 · 20 · 22 · 24 · 25
3X	18 · 19 · 20 · 22 · 24 · 25 · 28 · 30	18 · 19 · 20 · 22 · 24 · 25
4X	19 · 20 · 22 · 24 · 25 · 28 · 30 · 32	19 · 20 · 22 · 24 · 25 · 28 · 30
	35 · 38 · 40 · 42 · 45 · 48 · 50	32 · 35 · 38 · 40 · 42 · 45

* There is no keyway for bore diameter ø8 mm.
 * For the bore drilling standards, see P562.

Size	K1	B	C	C1	D	E	F	G	H	I	J	L	N	M1	M2
1X	12.5	20	30	23	42	15	30	5	25	22	3	50	6	2-M4	2-M4
2	16.5	25	41	32.5	55	20	35	11	35	32	5	66	7	2-M5	2-M5
2X	20.5	31	45	34	65	25	40	11	40	38	5	76	8	2-M5	2-M5
3	25.5	38	53	40	75	30	50	11	45	45	5	91	10	2-M6	2-M6
3X	25.5	36	85	41	75	30	80	11	45	45	6	121	10	2-M6	2-M6
4X	—	46	95	—	120	35	90	16	80	80	8	141	12	2-M10	2-M10

How to Place an Order

TT-2X-01-14N-19H-10NM-P

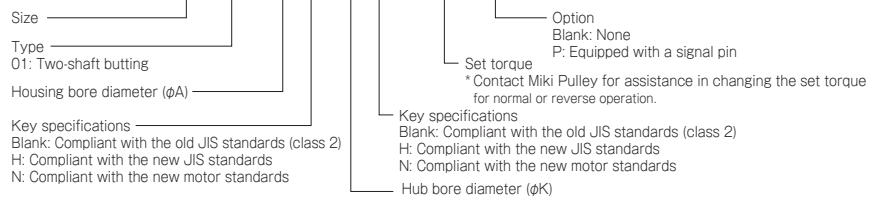

TT- □ -03 Types

Specifications

Type	Size	Set torque value [N·m]									Max. rotation speed [min ⁻¹]	Moment of inertia [kg·m ²]	Mass [kg]
		Spring color											
		Colorless	Blue	Red	Yellow	White	Gray	Green	Brown	Colorless			
TT-1X-03	1X	0.2	0.5	1.0	1.5	2.0	2.5	3.0	3.5	4.0	1800	0.09 × 10 ⁻³	0.4
TT-2-03	2	1	2	3	4	5	6	7	8	10	1800	0.31 × 10 ⁻³	0.8
TT-2X-03	2X	2	3	5	8	10	12	15	18	20	1800	0.66 × 10 ⁻³	1.1
TT-3-03	3	5	8	10	15	20	25	30	35	40	1800	1.59 × 10 ⁻³	1.7
TT-3X-03	3X	10	16	20	30	40	50	60	70	80	1800	2.43 × 10 ⁻³	3.0
TT-4X-03	4X	20	30	50	80	100	120	150	180	200	500	15.8 × 10 ⁻³	6.5

* The set torque values in the table above are those when the rotation speed is 1500 min⁻¹. The operation torque varies depending on the operating rotation speed. Please check P563.
 * If you need durability for the torque values in the shaded area, select a larger size.

- COUPLINGS
- ETP BUSHINGS
- ELECTROMAGNETIC CLUTCHES & BRAKES
- SPEED CHANGERS & REDUCERS
- INVERTERS
- LINEAR SHAFT DRIVES
- TORQUE LIMITERS**
- ROSTA

Dimensions

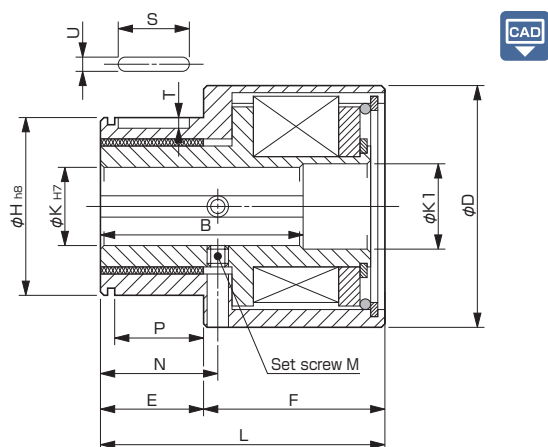

Unit [mm]

Size	Shaft bore dimensions in compliance with the new JIS standards
	K
1X	10 · 11 · 12
2	11 · 12 · 14 · 15 · 16
2X	14 · 15 · 16 · 18 · 19
3	18 · 19 · 20 · 22 · 24 · 25
3X	18 · 19 · 20 · 22 · 24 · 25
4X	19 · 20 · 22 · 24 · 25 · 28 · 30 · 32 · 35 · 38 · 40 · 42 · 45

Unit [mm]

Size	Shaft bore dimensions in compliance with the old JIS standards
	K
1X	8 · 10 · 11 · 12
2	11 · 12 · 14 · 15 · 16
2X	14 · 15 · 16 · 18 · 19 · 20
3	18 · 19 · 20 · 22 · 24 · 25
3X	18 · 19 · 20 · 22 · 24 · 25
4X	19 · 20 · 22 · 24 · 25 · 28 · 30 · 32 · 35 · 38 · 40 · 42 · 45

* There is no keyway for bore diameter ø8 mm.
 * For the bore drilling standards, see P562.

Unit [mm]

Size	K1	B	D	E	F	H	N	L	P	S	T	U	M
1X	12.5	34	42	20	35	30	25	55	16	14	2.5	4	2-M4
2	16.5	38	55	25	40	40	30	65	20	18	3	5	2-M5
2X	20.5	40	65	25	45	45	31	70	20	18	3	5	2-M5
3	25.5	52.5	75	35	55	60	45	90	30	28	4	7	2-M6
3X	25.5	75	75	35	90	60	45	125	30	28	4	7	2-M6
4X	46	100	120	50	90	85	57	140	45	40	4.5	12	2-M8

* The outer diameter key (old JIS class 2) and stop ring are included accessories.

MODELS

TT	
----	--

How to Place an Order

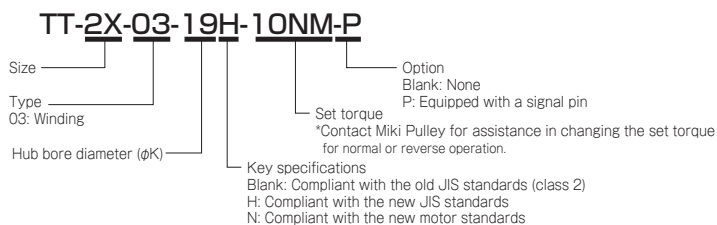

Torque Limiters

Standard Hole-Drilling Standards

- The set screws are included with the product.
- For standard bore drilling dimensions other than those specified, please contact Miki Pulley.
(A bore may not be able to be drilled for some hub sizes.)

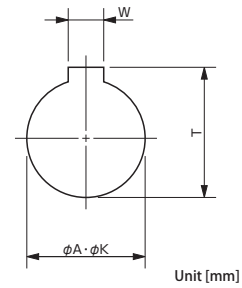

Unit [mm]

Models compliant with the old JIS standards (class 2)				Models compliant with the new JIS standards				Models compliant with the new motor standards			
Nominal bore diameter	Bore diameter $\phi A/\phi K$	Keyway width W	Keyway height T	Nominal bore diameter	Bore diameter $\phi A/\phi K$	Keyway width W	Keyway height T	Nominal bore diameter	Bore diameter $\phi A/\phi K$	Keyway width W	Keyway height T
Tolerance	H7	E9	+0.5 0	Tolerance	H7	H9	+0.5 0	Tolerance	G7	H9	+0.5 0
8	8 ^{+0.015} ₀	—	—	—	—	—	—	—	—	—	—
10	10 ^{+0.015} ₀	4 ^{+0.050} _{+0.020}	11.5	10 H	10 ^{+0.015} ₀	4 ^{+0.030} ₀	11.8	—	—	—	—
11	11 ^{+0.018} ₀	4 ^{+0.050} _{+0.020}	12.5	11 H	11 ^{+0.018} ₀	4 ^{+0.030} ₀	12.8	—	—	—	—
12	12 ^{+0.018} ₀	4 ^{+0.050} _{+0.020}	13.5	12 H	12 ^{+0.018} ₀	4 ^{+0.030} ₀	13.8	—	—	—	—
14	14 ^{+0.018} ₀	5 ^{+0.050} _{+0.020}	16.0	14 H	14 ^{+0.018} ₀	5 ^{+0.030} ₀	16.3	14 N	14 ^{+0.024} _{+0.006}	5 ^{+0.030} ₀	16.0
15	15 ^{+0.018} ₀	5 ^{+0.050} _{+0.020}	17.0	15 H	15 ^{+0.018} ₀	5 ^{+0.030} ₀	17.3	—	—	—	—
16	16 ^{+0.018} ₀	5 ^{+0.050} _{+0.020}	18.0	16 H	16 ^{+0.018} ₀	5 ^{+0.030} ₀	18.3	—	—	—	—
18	18 ^{+0.018} ₀	5 ^{+0.050} _{+0.020}	20.0	18 H	18 ^{+0.018} ₀	6 ^{+0.030} ₀	20.8	—	—	—	—
19	19 ^{+0.021} ₀	5 ^{+0.050} _{+0.020}	21.0	19 H	19 ^{+0.021} ₀	6 ^{+0.030} ₀	21.8	19 N	19 ^{+0.028} _{+0.007}	6 ^{+0.030} ₀	21.5
20	20 ^{+0.021} ₀	5 ^{+0.050} _{+0.020}	22.0	20 H	20 ^{+0.021} ₀	6 ^{+0.030} ₀	22.8	—	—	—	—
22	22 ^{+0.021} ₀	7 ^{+0.061} _{+0.025}	25.0	22 H	22 ^{+0.021} ₀	6 ^{+0.030} ₀	24.8	—	—	—	—
24	24 ^{+0.021} ₀	7 ^{+0.061} _{+0.025}	27.0	24 H	24 ^{+0.021} ₀	8 ^{+0.036} ₀	27.3	24 N	24 ^{+0.028} _{+0.007}	8 ^{+0.036} ₀	27.0
25	25 ^{+0.021} ₀	7 ^{+0.061} _{+0.025}	28.0	25 H	25 ^{+0.021} ₀	8 ^{+0.036} ₀	28.3	—	—	—	—
28	28 ^{+0.021} ₀	7 ^{+0.061} _{+0.025}	31.0	28 H	28 ^{+0.021} ₀	8 ^{+0.036} ₀	31.3	28 N	28 ^{+0.028} _{+0.007}	8 ^{+0.036} ₀	31.0
30	30 ^{+0.021} ₀	7 ^{+0.061} _{+0.025}	33.0	30 H	30 ^{+0.021} ₀	8 ^{+0.036} ₀	33.3	—	—	—	—
32	32 ^{+0.025} ₀	10 ^{+0.061} _{+0.025}	35.5	32 H	32 ^{+0.025} ₀	10 ^{+0.036} ₀	35.3	—	—	—	—
35	35 ^{+0.025} ₀	10 ^{+0.061} _{+0.025}	38.5	35 H	35 ^{+0.025} ₀	10 ^{+0.036} ₀	38.3	—	—	—	—
38	38 ^{+0.025} ₀	10 ^{+0.061} _{+0.025}	41.5	38 H	38 ^{+0.025} ₀	10 ^{+0.036} ₀	41.3	38 N	38 ^{+0.034} _{+0.009}	10 ^{+0.036} ₀	41.0
40	40 ^{+0.025} ₀	10 ^{+0.061} _{+0.025}	43.5	40 H	40 ^{+0.025} ₀	12 ^{+0.043} ₀	43.3	—	—	—	—
42	42 ^{+0.025} ₀	10 ^{+0.061} _{+0.025}	45.5	42 H	42 ^{+0.025} ₀	12 ^{+0.043} ₀	45.3	42 N	42 ^{+0.034} _{+0.009}	12 ^{+0.043} ₀	45.0
45	45 ^{+0.025} ₀	12 ^{+0.075} _{+0.032}	48.5	45 H	45 ^{+0.025} ₀	14 ^{+0.043} ₀	48.8	—	—	—	—
48	48 ^{+0.025} ₀	12 ^{+0.075} _{+0.032}	51.5	48 H	48 ^{+0.025} ₀	14 ^{+0.043} ₀	51.8	48 N	48 ^{+0.034} _{+0.009}	14 ^{+0.043} ₀	51.5
50	50 ^{+0.025} ₀	12 ^{+0.075} _{+0.032}	53.5	50 H	50 ^{+0.025} ₀	14 ^{+0.043} ₀	53.8	—	—	—	—

Optional Signal Pin

Unattended or remotely controlled machines and equipment require equipment that detects an overload and automatically switches off the power or sounds a warning alarm.

An overload can be detected by connecting the signal pin to the torque tender. When an overload is detected, the input side and the output side are disconnected and the cam mechanism of the torque tender hub pushes the signal pin out in the radial direction. This can be used to switch off the power or sound a warning alarm.

Be sure to use the housing as the input side.

The standard product cannot be modified to connect the signal pin. If you need to connect the signal pin, add [-P] to the end of the model when you order the product.

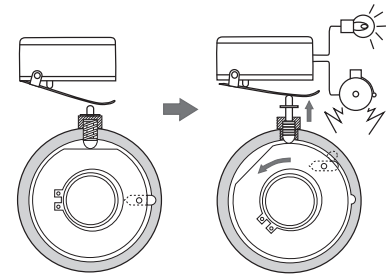

Size (TT-□-01-□-P)

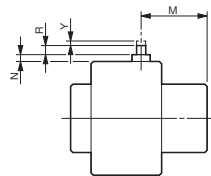

Unit [mm]

Size	M	Y	R	N
1X	24	1.5	6.5	5.5
2	29	2.5	5	4.5
2X	36	2.5	5	4.5
3	43	2.5	5	4.5
3X	42	2.5	5	4.5
4X	55	2.5	5	2

Size (TT-□-03-□-P)

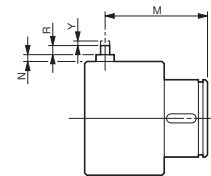

Unit [mm]

Size	M	Y	R	N
1X	47	1.5	6.5	5.5
2	56	2.5	5	4.5
2X	60	2.5	5	4.5
3	79	2.5	5	4.5
3X	114	2.5	5	4.5
4X	125	2.5	5	2

Items Checked for Design Purposes

Precautions for Use

1. Touching the product in operation with your hand or fingers may cause injury. Be sure to install a safety cover to prevent a hazard.
2. If the overload protection equipment is activated, the driving side and the driven side of the product are disconnected completely. Be sure to install a safety mechanism such as a safety brake to prevent a hazard.
3. The product is designed as overload protection equipment and is not designed as torque detection equipment. Never use it as torque detection equipment. Doing so may cause problems.
4. If the operation is continued while the overload protection mechanism is activated, the product may generate heat. If nothing is done, the product may be damaged and the equipment may be adversely affected. Be sure to install detection equipment, and if the overload protection mechanism is activated, immediately stop the operation of the equipment.
5. Do not use the product in a location where it may be exposed to corrosive gases and chemicals. The product is not waterproof so do not use it in a location where it may be exposed to water.
6. Do not use the product outside the operating temperature range of -40°C and 120°C.
7. All torque springs are inserted by us before delivery. If you want the set torque to be changed, please consult with our sales office. Do not disassemble and replace the spring.
8. Never use the product with a rotation speed other than the design one. If you use it with a rotation speed other than the design one, the driving side and the driven side will not be disconnected under a load under which you want to activate the overload protection mechanism, or will be disconnected under a load less than the one under which you want to activate the overload protection mechanism.
9. If the torque tender is activated by an overload, immediately stop the operation. Check to make sure that the main power of the equipment is switched off and then remove the cause for the overload on the driven side. When you connect the driving side and the driven side for recovery, manually rotate the driving side by applying a torque of more than 55% of the set torque at 1500 min⁻¹ to the driven side. Before restarting the operation, be sure to perform a start-up inspection and test run.
10. The mounting tolerance of the TT-□-01 type is 0.2 mm or less for the parallel misalignment and 0.5° or less for the angular deflection.
11. When you use an optional signal pin, pay attention to the following points.
 - * Make sure that the **housing is the input side**.
 - * Make sure that detection switches are installed in two positions away from each other at 120° or more in the rotation direction. An overload may not be detected with a single switch.
 - * The quality of the signal pin is good enough, but please install an additional detector other than the signal pin just in case.
12. There is backlash.

Selection

Determining the Operation Torque Value

Determine the operation torque value T of the torque tender based on the mechanical strength, load, and other conditions. If the operation torque cannot be determined based on the above conditions, it can be calculated with an expression of the rated output of the drive unit and the rotation speed of the shaft to which the torque tender is connected.

$$T = K \times \frac{9550 \times P}{n}$$

T: Operation torque [N · m]
 K: Service factor
 P: Drive unit rated output [kW]
 n: Torque tender rotation speed [min⁻¹]

Service Factor K

Directly connected to the motor	2.0 ~ 2.5
After changing speed	1.75 ~ 2.0
After deceleration	1.25 ~ 1.50
Rotation speed 25 min ⁻¹ or less	1.25

Selecting the Model and Set Torque

The operation torque changes as shown in the figure below as a result of the characteristics of the torque tender.

The set torque values of the torque tender are those when the rotation speed is 1500 min⁻¹. Accordingly, you need to read torque coefficient a at the rotation speed of the shaft to which the torque tender is connected from the figure below, and convert it to the set torque at 1500 min⁻¹ using the following expression.

$$T_s = \frac{T}{a}$$

T: Operation torque [N · m]
 a: Torque coefficient
 T_s: Set torque at 1500 min⁻¹ [N · m]

From the specification table, select the size whose set torque value is closest to T_s that was calculated with the expression above.

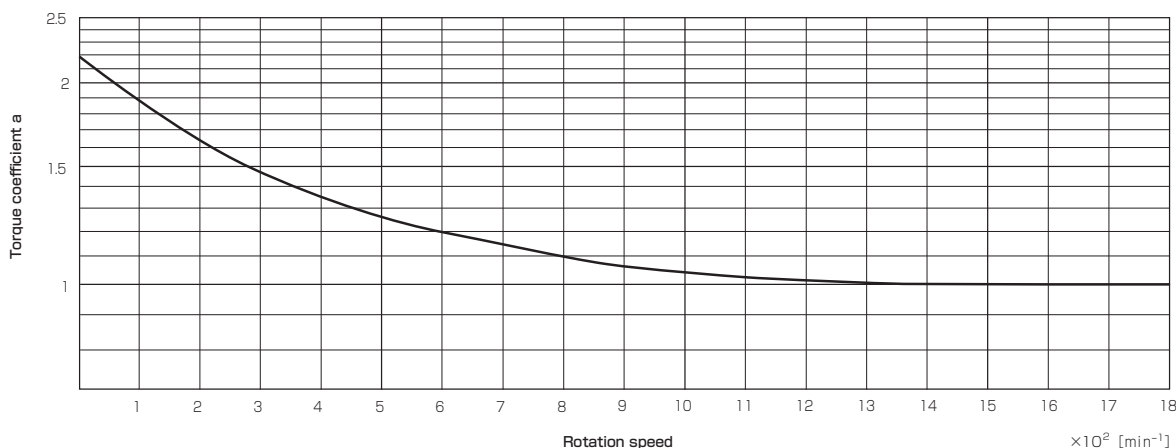

* Use size 4X at a rotation speed equal to or less than 500 min⁻¹.

COUPLINGS

ETP BUSHINGS

ELECTROMAGNETIC
CLUTCHES & BRAKESSPEED CHANGERS
& REDUCERS

INVERTERS

LINEAR SHAFT DRIVES

TORQUE LIMITERS

ROSTA

MODELS

TT